



axxess



The AXCESS series in-desk box has been designed around the customer's needs and requirements to provide a stylish, contemporary and practical power, data and AV solution.

The AXCESS is manufactured using environmentally safe and recyclable components and is the ideal solution to provide Power, Data and AV to your desktop, workstation or boardroom table. The unique design of the AXCESS also allows cables to be stored within the unit when not in use.

The AXCESS comes in two standard sizes and the undercarriage can be banked together to allow almost any length AXCESS that is required. The unique locking arm system ensures that the AXCESS is securely fitted to the table/desktop by operating screws at each end of the AXCESS and once fixed, the locking screws are covered with a discreet screw cap cover.

A unique feature of the AXCESS lid is the cable guides which are attached to either end that guide the cables towards the smaller cable flap thereby avoiding damage to the cables.

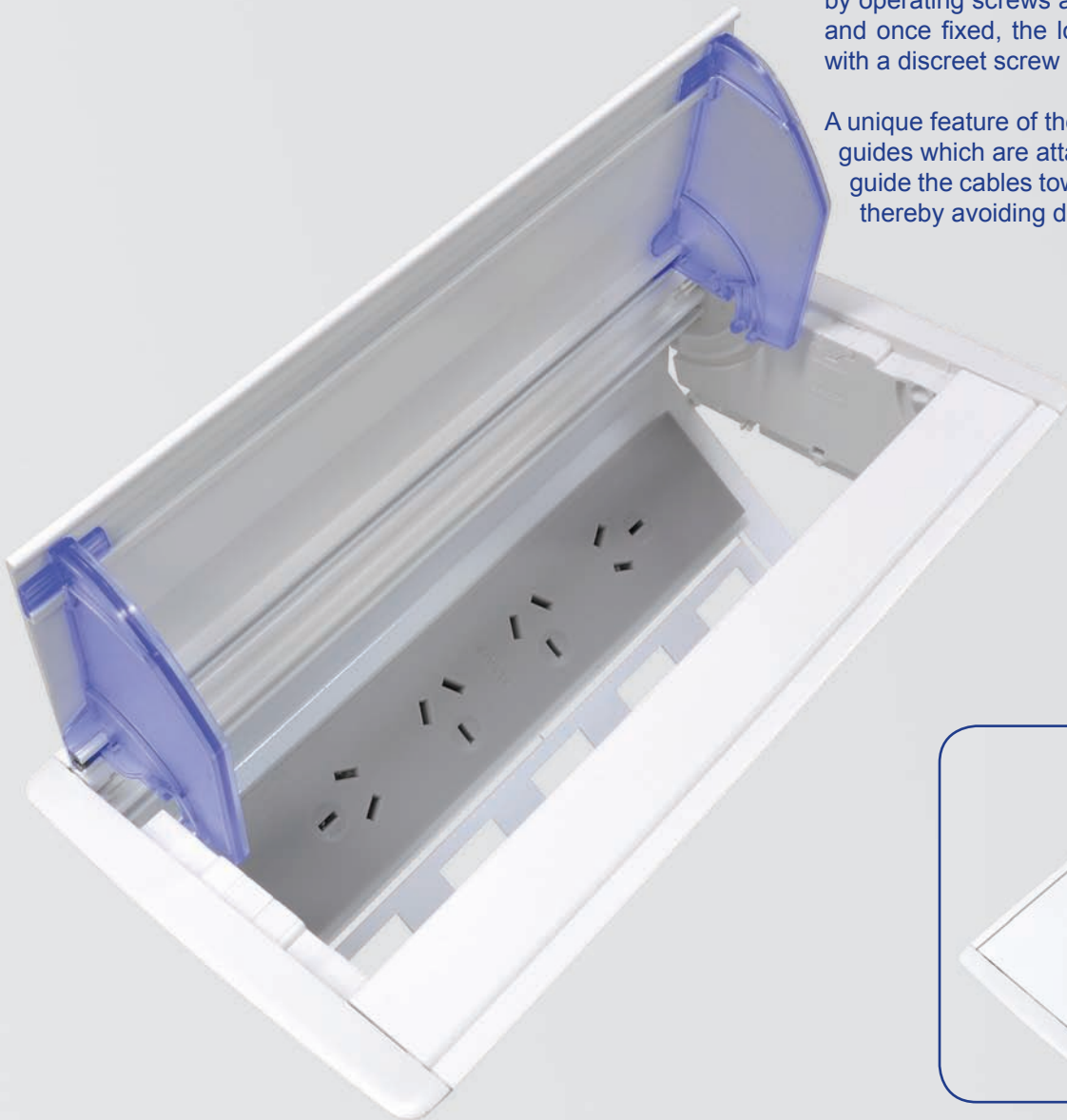

Version: 2011.10.07.



**Elsafe Australia Pty Ltd**

**Sydney**  
Tel: +61 (2) 9454 7500  
Fax: +61 (2) 9454 7505  
Email: sales@elsafe.com.au

**Melbourne**  
Tel: +61 (3) 9840 1321  
Fax: +61 (3) 9840 0159  
Email: vic@elsafe.com.au

**Brisbane**  
Tel: +61 (7) 3399 7099  
Fax: +61 (7) 3399 9133  
Email: qld@elsafe.com.au

*service - quality - safety*

[www.elsafe.com.au](http://www.elsafe.com.au)

## Common Components

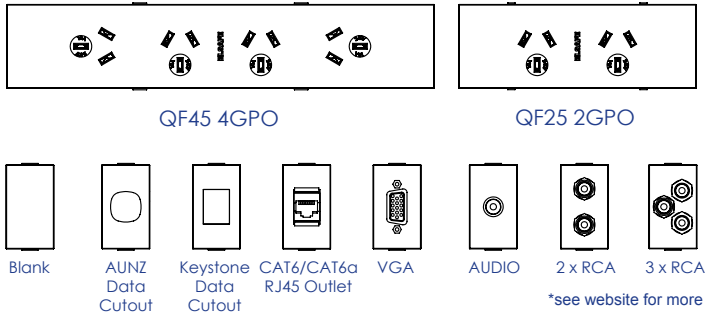

QF5 Tiles to provide Data and AV solutions

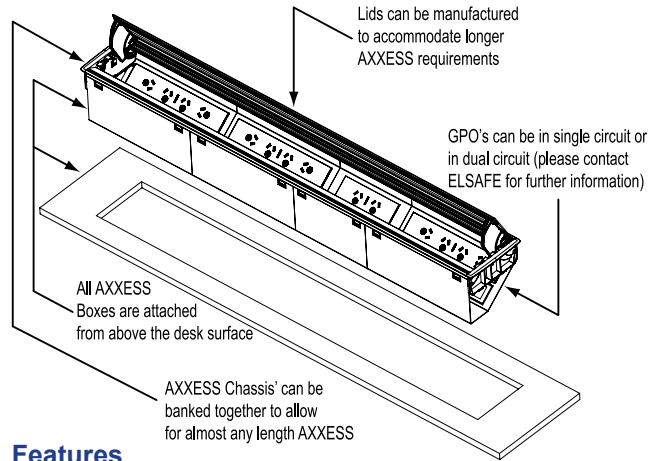
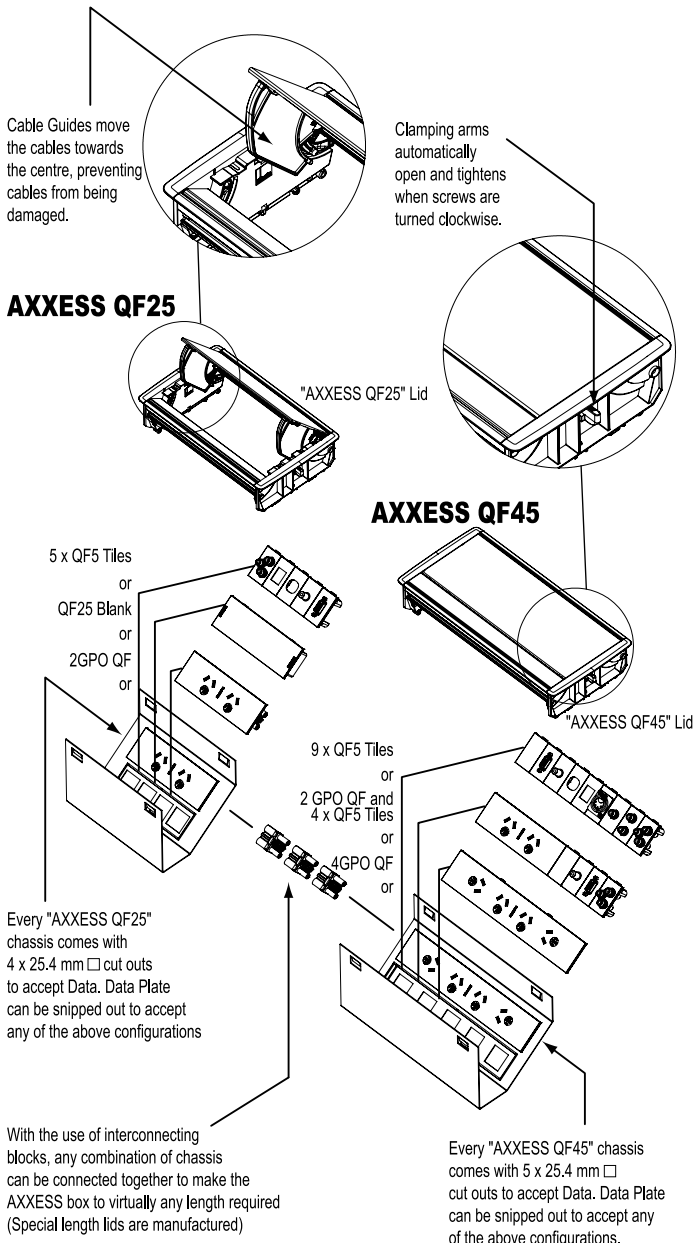

## Features

### Configuration:

Power only / Data only / AV only / Combined (power, data and/or AV) AXCESS Chassis units can be banked together (as per image above) allowing for almost any length configuration.

### AXCESS Lids:

AXCESS Lids come in two standard sizes. Longer lids are manufactured accordingly when a longer AXCESS chassis is required. AXCESS lids can also be purchased on their own without the chassis as a through desk solution.

### Testing:

100% testing-continuity, polarity, insulation & earth

### Insulation:

Reinforced insulation

### Soft Wiring (power):

Power via Wieland GST connector allows starter cables to be changed to suit requirements, especially useful during moves and changes (CHURN)

### Cutout dimensions

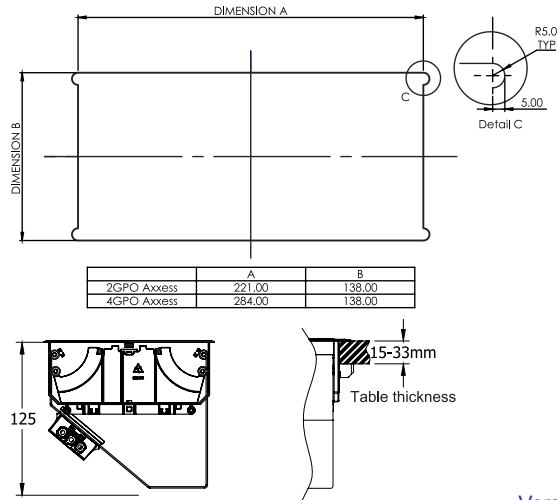

Version: 2011.10.07.

